

COHU, INC. Electronics Division

Installation and Operation Instructions

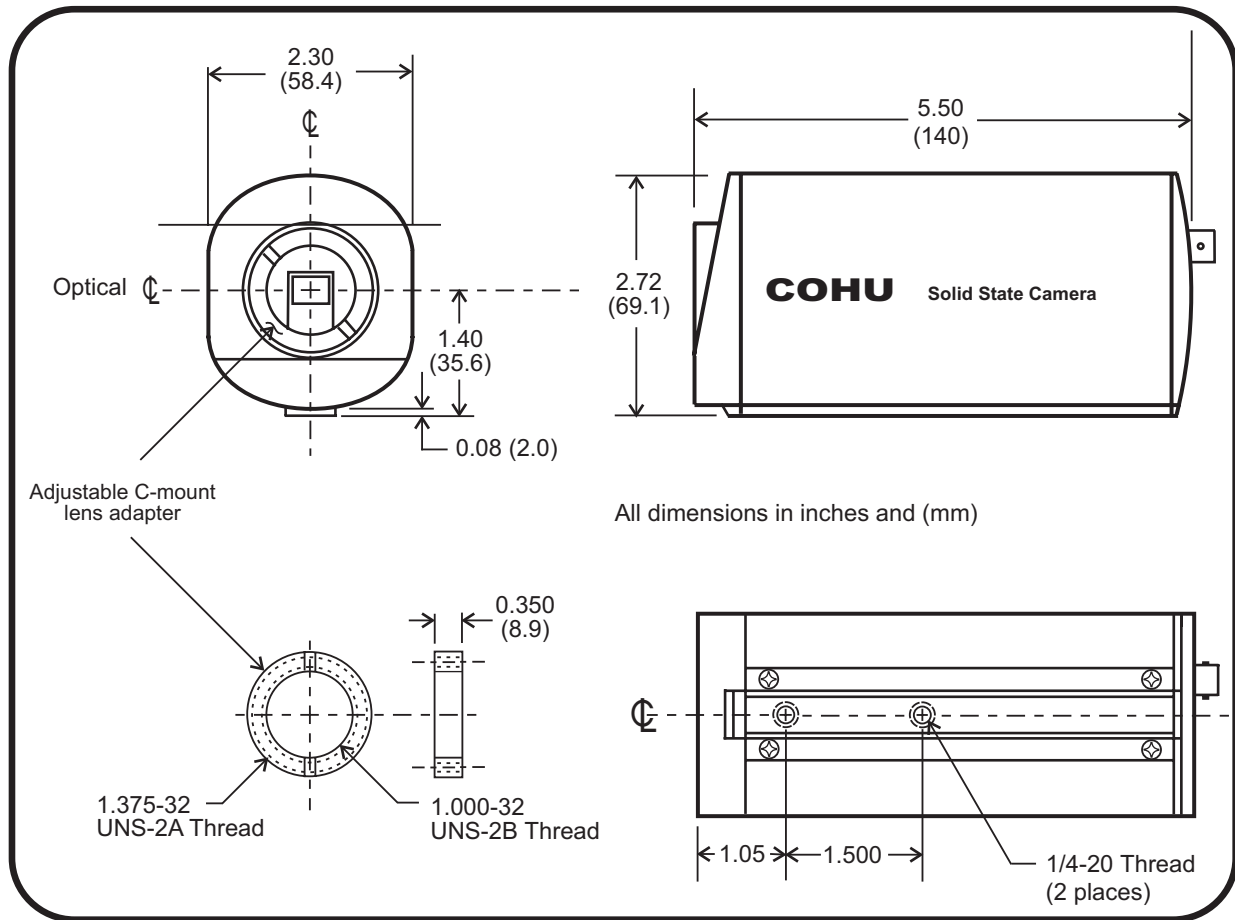

Figure 1. Dimensions

6310 SERIES MONOCHROME CAMERAS

COHU ELECTRONICS
3912 CALLE FORTUNADA
SAN DIEGO, CA 92123-1827

PHONE: 858-277-6700
FAX: 858-277-0221
E-MAIL: info@cohu.com

6X-931(A)

COHU
Cohu, Inc. Electronics Division

TABLE 1. SPECIFICATIONS

ELECTRICAL	
Imager	Single CCD using frame transfer method
Pickup Area	6.4 x 4.8 mm (1/2 inch format)
Active Picture Elements	739 (H) x 484 (V) (frame transfer)
Cell Size	8.5 μm (H) x 19.5 μm (V)
Resolution	Horizontal: 550 TV lines Vertical: 350 TV lines
Sensitivity	2850 K faceplate sensitivity. See table 1a
Contrast Variation at 25 °C	<15%
Video Output	1 V p-p, 75 Ohms, unbalanced
Gamma	Can be set from 0.5 to 1.0 with board potentiometer
Agc	Repositionable jumper select on-off; peak/average adjustable 20 dB
Auto Black	Maintains setup level at 7.5±5 IRE units if the picture contains at least 10% black
Signal-to-Noise Ratio	56 dB at gamma 1, agc Off, 8 MHz bandwidth, unweighted
Auto Lens Drive Signal	Peak average characteristic tracks agc adjustment to eliminate agc/auto-lens interaction
Sync	<ul style="list-style-type: none"> •EIA RS-170 crystal, 14.318 MHz clock output (standard) •Genlock External sync input with crystal or line lock backup (jumper select) •External H and V drive inputs
Power Requirements	12 V ac/dc ±10%, 4.2 watts
ENVIRONMENTAL	
Ambient Temperature Limits	Operating: -10 to 50 °C (14 to 122 °F) Storage: -30 to 70 °C (-22 to 158 °F)
Humidity	Up to 95% relative humidity, noncondensing
Vibration (less lens)	5 to 60 Hz with 0.082 inch total excursion (15 g's at 60 Hz) From 60 to 1000 Hz, 5 g's rms random vibration without damage
Shock (less lens)	Up to 30 g's in any axis under nonoperating conditions, MIL-E-5400T, paragraph 3.2.24.6
Altitude	Sea level to equivalent of 3,000 m /10,000 feet (500mm/20 inches of mercury)
MECHANICAL	
Weight (less lens)	425 grams (15 oz)
Dimensions	See figure 1
Camera Mount	1/4-20 threaded holes
Lens Mount	C-mount

TABLE 1a. SENSITIVITY

Video Level	With IR Blocking Filter	Without IR Blocking Filter
Full Video, agc Off	0.40 fc (4.0 lux)	0.03 fc (0.3 lux)
90% Video, agc On	0.036 fc (0.36 lux)	0.0027 fc (0.027 lux)
Usable Picture, 30% Video, agc On	0.0012 fc (0.012 lux)	0.0009 fc (0.009 lux)

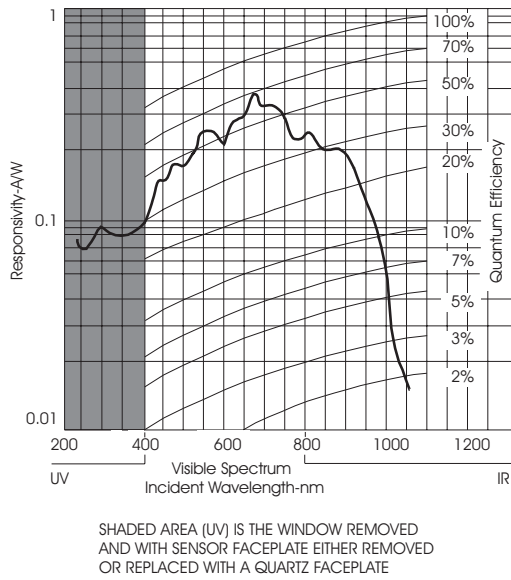

Fig. 2. Spectral Response

1.0 ELECTRICAL CHARACTERISTICS

The Camera features a 1/2-inch format Charge Coupled Device (CCD) image sensor. The sensor uses the frame transfer method, with an active imaging area measuring 6.4 by 4.8 mm (1/2 inch format). The active imaging area is an array of 739 horizontal by 484 vertical picture elements, providing a horizontal resolution of 550 lines and a vertical resolution of 350 lines. Camera scanning is 2:1 interlace to RS-170 standards.

Video output is 1.0 volt peak-to-peak. A 75-ohm, source-terminated, single-ended video output is provided on the rear panel (fig. 4).

The Camera will genlock to an RS-170 composite-video or -sync source, or to horizontal and vertical external drive. The Camera will revert to either crystal or line lock (switch selectable) upon loss of the external sync signal.

2.0 MECHANICAL CHARACTERISTICS

The Camera is a compact, lightweight unit weighing 15 ounces (425 grams) without the lens. All interfacing connectors are located on the rear panel for easy access. The C-mount adapter accepts most types of manual- and auto-iris televi-

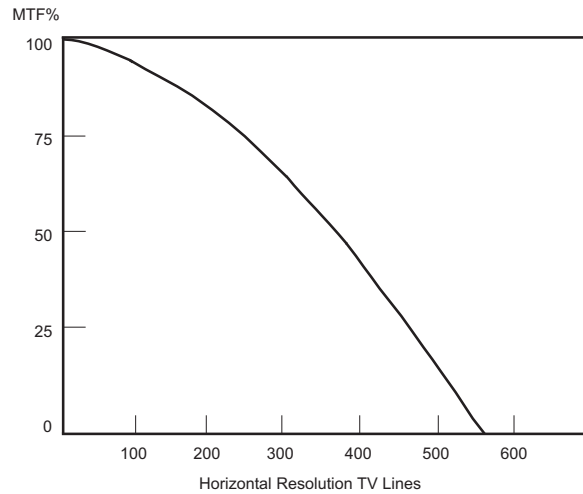

Fig. 3. Modulation Transfer Function

sion lenses. Two 1/4-20 tapped holes are provided on the base for mounting (fig. 1).

3.0 POWER REQUIREMENTS

The Camera requires 12-V dc/ac, 60-Hz input power, depending on the model. The Camera operates from 115-V 60-Hz ac power when used with the optional external power pack (fig. 5).

4.0 EQUIPMENT SUPPLIED

The following list does not include any optional or special-request items. A lens ordered with the Camera will either be installed on or packed with the Camera.

1. 6310 Camera
2. Installation and Operation Manual 6X-931(A)
3. C-mount adapter, part No. 2010637-350
4. Auxiliary connector plug (for J30 on rear panel), part No. 1310349-006
5. Power connector plug (for J38 on rear panel) part No. 1310356-103

TABLE 2. MODEL NUMBER INTERPRETATION

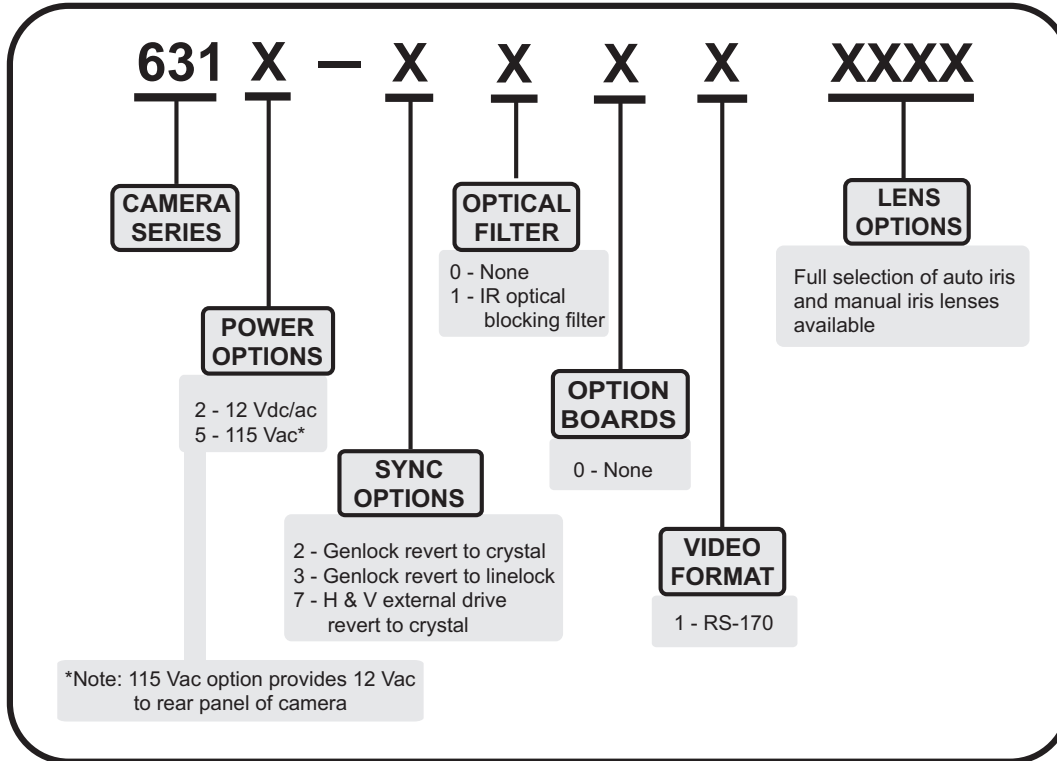

6. Auto iris lens connector plug (for J32 on rear panel) part No. 1310356-104 with strain relief part No. 1310356-401

The plug for J38 is not supplied if the 115-V ac power pack is shipped with the Camera. The plug for J32 is installed on the lens connector if a lens is ordered with the Camera. Plugs are not supplied for rear panel connectors in which a cable is provided. These interconnecting cables may be supplied with other equipment.

5.0 EQUIPMENT REQUIRED BUT NOT SUPPLIED

The following items are the minimum required to make use of the Camera. A tv picture monitor will be highly desirable for focusing and other adjustments even if the Camera will be used in an application that does not require direct visual monitoring of the Camera output. Use only high quality 75 ohm coaxial cable.

1. 115-V ac, 60-Hz power pack, or 12-V dc/ac, 60 Hz power supply (depending on the model)

2. C-mount television lens

3. 75-ohm coaxial cable. Cable with copper covered iron conductors can cause problems on long runs. It is best to avoid this type cable.

4. RS-170 television monitor

6.0 UNPACKING AND RECEIVING INSPECTION

This item was thoroughly tested and carefully packed in the factory. Upon acceptance by the carrier, they assume responsibility for its safe arrival. Should you receive this item in a damaged condition, apparent or concealed, a claim for damage must be made to the carrier. To return the product to the factory for service, please contact the Customer Service Department for a Return Authorization Number.

If a visual inspection shows damage upon receipt of this shipment, it must be noted on the freight bill or express receipt and the notation signed by the carrier's agent. Failure to do this can result in the carrier refusing to honor the claim.

When damage is not apparent until the unit is unpacked, a claim for concealed damage must be made. Make a mail or phone request to the carrier for inspection immediately upon discovery of the concealed damage. Keep all cartons and packing materials. Since shipping damage is the carrier's responsibility, the carrier will furnish you with an inspection report and the necessary forms for filing the concealed-damage claim.

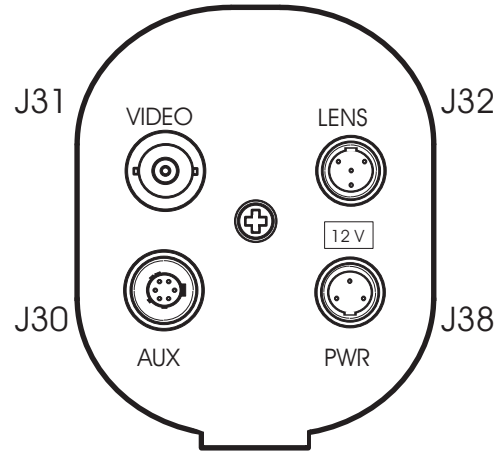

Fig. 4. Rear Panel

7.0 STATIC DISCHARGE PROTECTION

Components used in modern electronic equipment, especially solid-state devices, are susceptible to damage from static discharge. The relative susceptibility to damage for semiconductors varies from low with TTL to high with CMOS. Most other semiconductors fall between TTL and CMOS in susceptibility to static discharge.

As a minimum, therefore, observe the following practices when working inside this or any other electronic equipment:

1. Use conductive sheet stock on the work bench surface.
2. Connect the sheet stock to ground through an approximate 1 megohm resistor.
3. Use a wrist strap connected to ground through an approximate 1 megohm resistor when working at the bench.
4. Maintain relative humidity of the room above 30 percent. This may require a room humidifier.

Working on circuits when relative humidity is below 30 percent requires extra procedures not listed here.

5. Use static-proof bags to store and transport the Camera chassis, circuit boards, and components. Use new static bags. Old, used bags lose their static protection properties.

This list serves as a reminder of the minimum acceptable practices. Be sure that all static discharge devices at the work bench are properly installed and maintained.

Standard grounding sheets and wrist straps purchased for use at work benches are supplied with leads having the required current limiting resistors for safety. Never substitute a lead that does not have a resistor.

8.0 INSTALLATION PROCEDURE

Installation consists of:

Table 3. Interfacing Connectors

Name	Camera Rear Panel Connector		Mating Connector For Cable	
VIDEO (J31)	1310242-011	BNC Jack	1310212-001	BNC Plug
AUXILIARY (J30)	1310348-006	(Hirose SR30-10R-6S)	1310349-006	(Hirose SR30-10PE-6P)
POWER (J38)	1310356-003	(Switchcraft TB3M)	1310356-103	(Switchcraft TA3F)
LENS (J32)	1310356-004	(Switchcraft TB4M)	1310356-104	(Switchcraft TA4F)

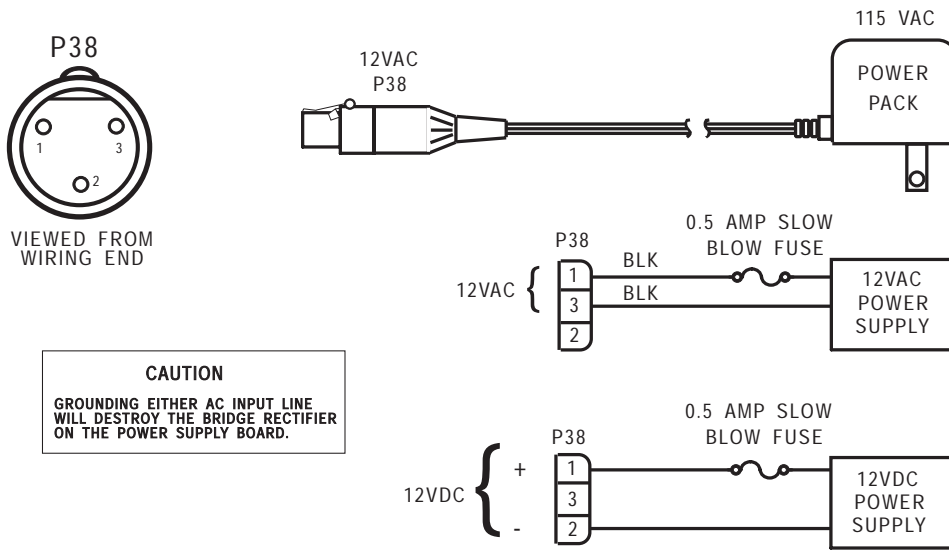

Fig. 5. Power Connections

1. Connecting power, video, and (if required) sync cables.
2. Installing the lens and checking back focus (if required).
3. Setting up internal circuits for the intended application (if required).
4. Mounting the Camera at its location.

8.1 Power Connection

The Camera requires 12-V dc/ac, 60 Hz input power. To operate the Camera from a 115-V ac 60-Hz power source, use the optional power pack (fig. 5). Do not ground either ac input line to the Camera rear panel. A ground will destroy the bridge rectifier.

Be careful of polarity when making dc power connections. A 0.5 amp time-lag fuse is recommended when not using the optional power pack.

CAUTION

Do not allow voltage excursions outside the recommended operating range of the Camera (10.8 to 13.2 V ac/dc at the Camera rear panel input, or 103.5 to 126.5 V ac at the external wall transformer).

CAUTION

Do not operate more than one Camera from the 12 V ac source. Paralleling two or more Cameras will damage the bridge rectifiers.

8.2 Video Connections

Connect J31 on the rear panel (fig. 4) to the tv monitor using 75 ohm (RG-59/U) coaxial cable. Terminate the monitor with a 75-ohm impedance. Multiple monitors may be interconnected in a loop-through arrangement, with only the last monitor in the chain terminated.

8.3 Lens Installation

Refer to figure 6 for the auto lens connector (P32) wiring diagram.

1. Remove the protective covering from the lens C-mount adapter opening.
2. Clean the lens and the faceplate of the sensor. Use methyl alcohol or an optical-quality solution and a cotton swab. Never rub an optical surface with a dry swab.

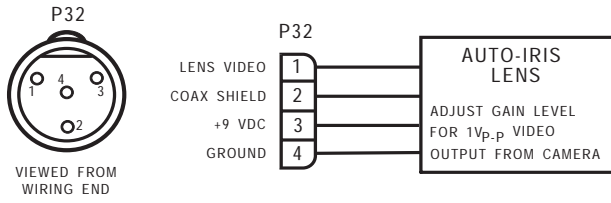

NOTE

Fig. 6. Auto Iris Lens Connections

3. Check the C-mount adapter setscrew and make sure it is snugged down. Be careful not to over-tighten.

4. Screw the lens into the C-mount adapter. Snug down so the two will turn as one unit when the set-screw is loosened for back focus adjustments.

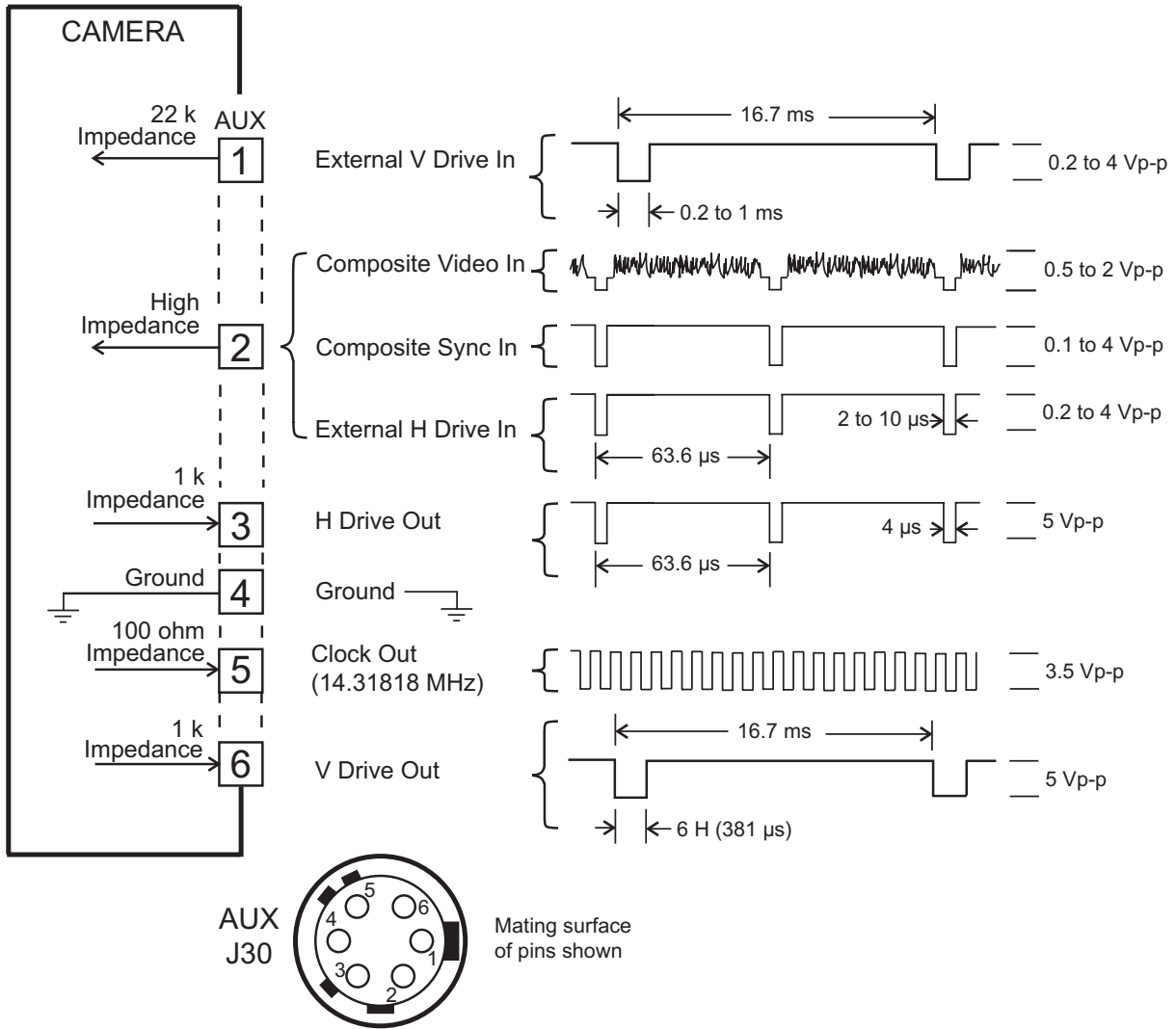

Fig. 7. Auxiliary Connector and Waveforms

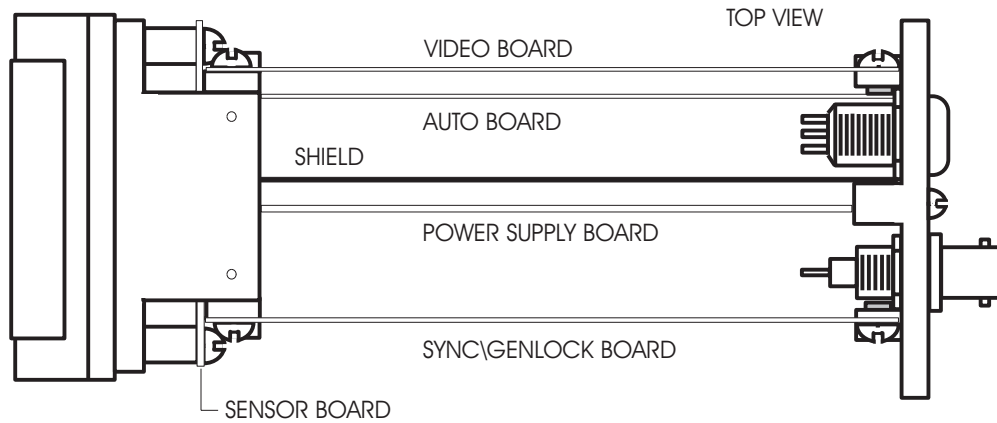

Fig. 8. Location of Circuit Boards

5. If an auto lens is used, plug the lens cable (P32) into the lens connector (J32) on the rear panel.

8.4 Sync and External Drive Connections

The auxiliary connector provides composite-sync and -video genlock inputs, horizontal and vertical external drive inputs, horizontal and vertical trigger outputs, and a 14.318180-MHz clock output. Connector pin-outs and waveforms are shown in figure 7.

If vertical lines appear after changing sync sources, the black balance and white balance potentiometers on the video board may need adjustment. See table 4.

8.5 Back Focus Adjustment

An IR-rejecting filter will help prevent focus shift if scene illumination varies between light with large amounts of IR (sunlight or incandescent bulbs) and light with little IR (fluorescent).

1. Set the lens focusing ring to infinity.
2. Point the camera at a distant scene well into the infinity focusing distance of the lens.
3. Place sufficient neutral density (ND) filters in front of the lens so the lens iris is fully open with normal video output.
4. Note whether the scene is in sharp focus. If it is, no further adjustments are required.

5. If the scene is out of focus, loosen the C-mount setscrew and rotate the lens and C-mount as a unit in and out of the camera until the scene is in focus.

6. Snug down the setscrew. Do not overtighten.

7. Remove ND filters slowly to allow the lens iris to close.

8.6 Auto Iris Lens Gain

With an auto iris lens the video viewed on a monitor may pulsate under bright lighting conditions. If this happens, the gain on the auto iris lens may require adjustment. To readjust gain on the lens, proceed as follows:

1. Remove the rear plate from the Camera and

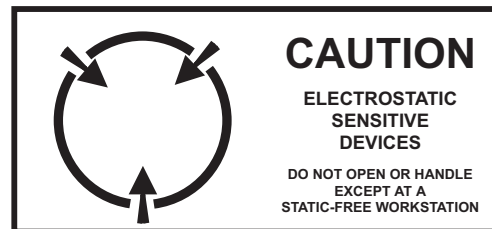

slide the cover off.

2. Place the agc jumper in the OFF position.
3. Adjust the gain potentiometer on the auto iris lens to obtain an acceptable picture on the monitor.

TABLE 4. ADJUSTMENTS

ADJUSTMENT / JUMPER	FUNCTION
SYNC/GENLOCK Board (Figure 9)	
XTAL/LL (S1) (Crystal / Line-Lock)	<p>For crystal-controlled operation or if dc power is used without genlock or H and V drive, this switch must be in the XTAL position.</p> <p>For line lock operation this switch must be in the LL position. When using genlock mode the camera reverts to the operating mode selected by the switch on removal of the external sync signal.</p> <p>Note: Operation in line lock sync mode requires low-voltage 60 Hz ac input to camera</p>
VIDEO Board (Figure 10)	
GAMMA (R94) 0.5 / 1.0	<p>When rotated fully ccw (gamma 1.0) this control provides a linear video output relative to black and white levels. Rotating the control cw provides an increasingly nonlinear response favoring blacks until a gamma of 0.5 is reached. This control provides a means of compensating for the nonlinear characteristic of picture tubes. Use 0.5 when viewing video on a picture tube. Use 1.0 with linear viewing devices.</p>
A-B (JB2) ON / OFF	<p>This auto black jumper selects automatic or manual black level (setup). In the ON mode the darkest part of the picture adjusts to the setup level automatically. In OFF mode this function is disabled. Agc must be ON when A-B is ON</p>
AGC (JB1) ON / OFF	<p>For automatic gain control, place jumper in the ON position. Must be ON when A-B is ON</p>
SETUP (R100)	<p>This control sets the video black reference level (setup) when the A-B jumper is in the OFF position. Typical setting is 7.5 IRE units (53 mV) above blanking</p>
BB1 and BB2 (R41 and R46)	<p>Adjust to remove vertical interference lines. Cap lens and adjust black balance 1 and 2. Then go to white balance adjustments.</p>
WB1 and WB2 (R37 and R38)	<p>Adjust to remove vertical interference lines. View white field, being careful not to overdrive camera, and adjust white balance 1 and 2. Repeat black and white balance adjustments until lines are minimized.</p>
BB3 (R93)	<p>This control adjusts the black level (setup) to compensate for black level shift when agc gain is at maximum.</p>
AUTO Board (Figure 11)	
PK-AVG (R37)	<p>Adjusts agc sensing between peak detect (ccw) and average detect (cw). In the PK (peak) detect position agc holds the video peak levels to 100 IRE. In the AVG (average) position agc averages the video white levels to 100 IRE.</p>
AUTO BLK (R64)	<p>This control sets black level when the A-B jumper (video board) is in the ON position</p>
<p><i>NOTE: These controls and jumpers are shown with shading in figures 9, 10, and 11</i></p>	

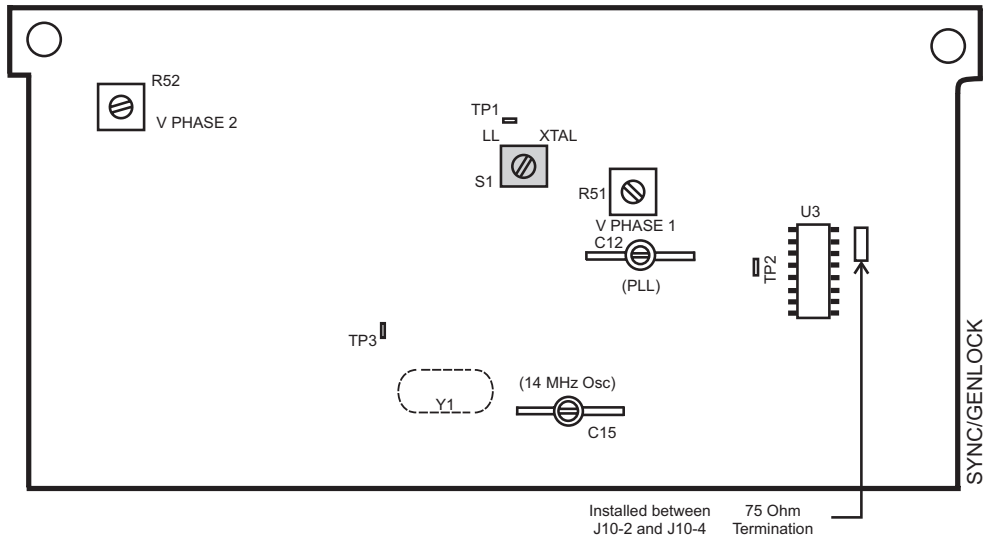

Fig. 9. Adjustment Locations, Sync/Genlock Board

4. Place the agc jumper in the ON position and note that the picture remains normal. Readjust lens gain if necessary.
5. Replace the cover and rear plate.

9.0 INSTALLATION ADJUSTMENTS

Cameras are shipped with adjustments set for operation under typical conditions, or as requested by the user. Some user adjustments and jumpers are available to change Camera operating conditions.

Figure 8 shows board locations. Figures 9 through 11 show adjustment locations. Adjustments listed in table 4 can be used to change operating conditions related to various applications of the Camera. Adjustments not listed in table 4 are setup adjustments that require procedures given in the maintenance manual. Perform maintenance adjustments only when section 5.4 of the maintenance manual is being followed. Be aware that adjusting anything electrical or mechanical without the proper procedure may void the warranty of a

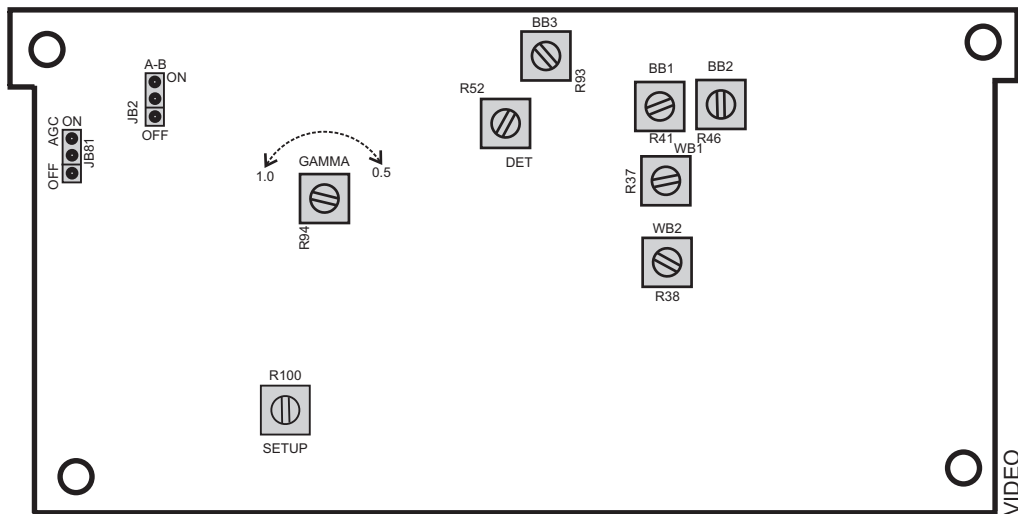

Fig. 10. Adjustment Locations, Video Board

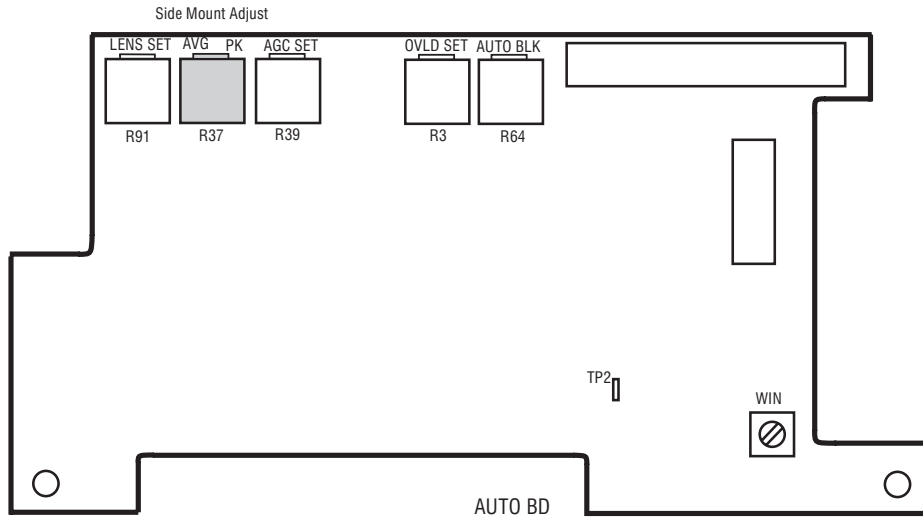

Fig. 11. Adjustment Locations, Automatics Board

new Camera. Refer to the WARRANTY statement in this manual.

10.0 PREPARATION FOR SHIPMENT AND STORAGE

For storage periods exceeding about one month, seal the unit in a vapor-proof bag containing a fresh desiccant pack. Maintain the Camera storage environment within -30 to 70 °C (-22 to 158 °F).

For shipment, package with enough foam padding or other packing material to prevent damage that can occur during shipping. The original shipping carton is a good container if it has not been damaged or subjected to excessive moisture.

For shipping to the factory by Common Carrier, use 3912 Calle Fortunada, San Diego, CA 92123-1827 as the address. Please contact the Customer Service Department for a Return Authorization Number before sending any shipments to the factory.

WARRANTY

Cohu, Inc., Electronics Division, warrants equipment manufactured to be free from defects of material and workmanship. Any part or parts will be repaired or replaced when proven by Cohu examination to have been defective within two years from date of shipment to the original purchaser for standard CCD cameras and one year from date of shipment to the original purchaser for intensified CCD cameras and all other Cohu manufactured products.

All warranty repairs will be performed at the factory or as otherwise authorized by Cohu in writing. Transportation charges to Cohu shall be prepaid by purchaser.

This warranty does not extend to Cohu equipment subjected to misuse, accident, neglect, or improper application, nor repaired or altered by other than Cohu or those authorized by Cohu in writing. Television image pickup tubes, image intensifiers, lenses, and products manufactured by companies other than Cohu are warranted by the original manufacturer. This warranty is in lieu of all other warranties expressed or implied. Cohu shall not be liable for collateral or consequential damages.

A Return Authorization (R A) number must be obtained from Cohu prior to returning any item for warranty repairs or replacement.

**COMPLIES WITH FEDERAL COMMUNICATIONS COMMISSION
RULES AND REGULATIONS
PART 15 FOR CLASS A DIGITAL DEVICES**

NOTE This equipment has been tested and found to comply with the limits for a Class A digital device, pursuant to part 15 of the FCC rules. These limits are designed to provide reasonable protection against harmful interference when the equipment is operated in a commercial environment. This equipment generates, uses, and can radiate radio frequency energy and, if not installed and used in accordance with the instruction manual, may cause harmful interference to radio communications. Operation of this equipment in a residential area is likely to cause harmful interference in which case the user will be required to correct the interference at his own expense.

This device complies with part 15 of the FCC Rules. Operation is subject to the following two conditions: (1) This device may not cause harmful interference, and (2) this device must accept any interference received, including interference that may cause undesired operation.

Complies with VDE, 0871, Class B Requirements

COHU
Cohu, Inc. Electronics Division

July 2, 1997
Revision 1 September 25, 1997
Revision 2 January 25, 2000